

**CAUTION!** ONLY BALL ENDED HEX WRENCHES SHALL BE USED TO TIGHTEN OR LOOSEN SCREW TO AVOID HIGH LATERAL LEVERING OF THE SMT STAPLE WHICH COULD LEAD TO STAPLE SEPARATION. CONSIDER USE OF THE SLOTTED SCREW TO MINIMIZE THIS ESPECIALLY FOR FIELD WIRING USE.

14257-SMT parts screw torquing precautions - Slotted and Hex driving means  
Steel screws (75C version) and Aluminum screws (90C versions)

When torquing the wire binding screw to the proper amount for the size of wire, all SMT versions using the 14257-SMT staple bus must be protected against lateral forces ( 90 degrees to the axis of the staple length) when driving the screw which is the weaker plane for the SMT soldered connection to the PCB (the narrow plane of the staple).

Tearing detachment of the SMT soldered joint can occur do to its inherent weakness in that plane.

A universal jointed bit holder, universal joint coupling or universal "wobble" ended extension driver must always be used to apply pure rotational torque and no lateral torque moments.

SEE ALSO IHI GUIDE TO SMT COMPONENTS BEFORE USING SMT COMPONENTS IN DESIGNS

**CONDITIONS OF ACCEPTABILITY** ARE NOMINALLY PROVIDED BY THE TURN PREVENT STAPLES OF MINIMUM REQUIRED CROSS SECTION IN CONJUNCTION WITH ADEQUATE PCB STRUCTURE.

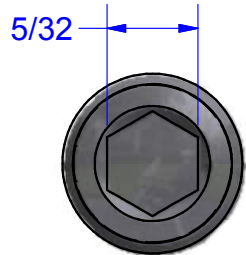
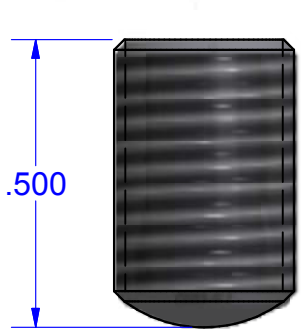

SCREW #12786-HEX STEEL (ZINC PLATED)

**PARTS MARKED**

- B2C
- IHI LOGO
- CSA LOGO
- UL REGOGNITION LOGO
- 2-14CU7
- 2-8AL7

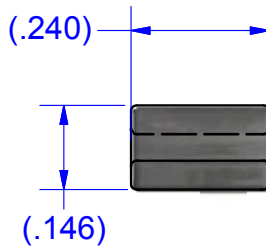
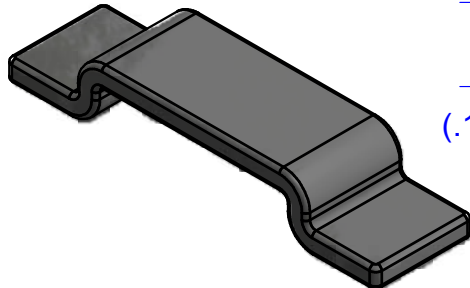

BUS #14257-SMT COPPER (TIN SOLDERABLE)

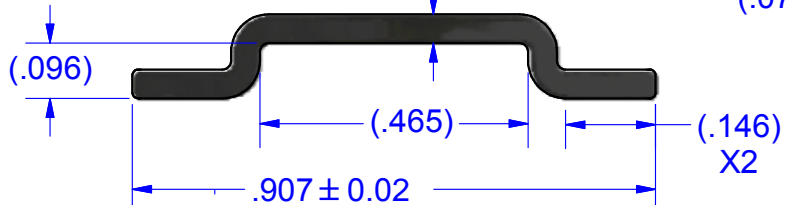

THIS DRAWING AND DESIGN ARE THE PROPERTY OF INTERNATIONAL HYDRAULICS, INC., CLEVELAND, OHIO, AND MAY NOT BE DUPLICATED, USED FOR THE BASIS OF DESIGN OR MANUFACTURE WITHOUT THE WRITTEN PERMISSION OF INTERNATIONAL HYDRAULICS, INC., CLEVELAND, OHIO.

INTERNATIONAL HYDRAULICS, INC.

TITLE:  
**Connector + Bus for PCB Mount**  
**ASSEMBLED CONNECTOR**

GENERAL TOLERANCES  
±.015 (±0,038mm)

MATERIAL:  
**SEE ABOVE**

SIZE: DWG NO.:  
TDS B2C-PCB-SMT-HEX (SALES) REV:

FINISH:

DATE:  
**6/29/09**

THIS IS A CAD DRAWING, DO NOT MANUALLY REVISE

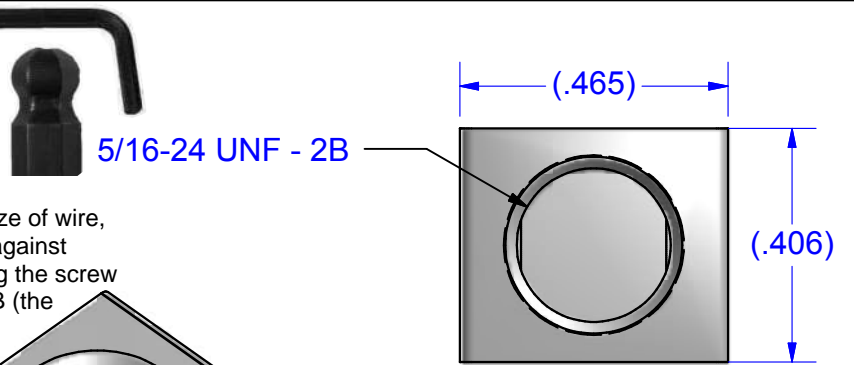

CONNECTOR #B2C ALUMINUM (TIN PLATED)

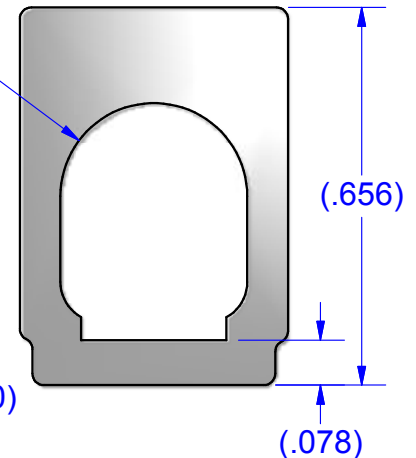
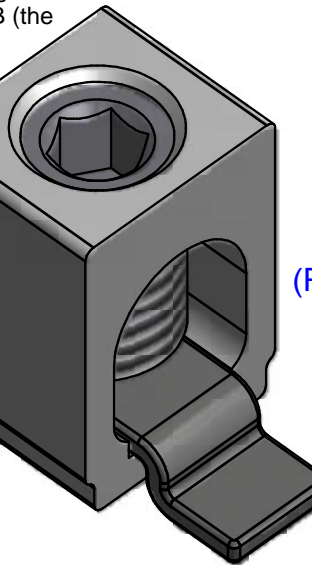

NOT FOR USE WHERE FAILURE CREATES A HAZARD TO HUMAN HEALTH OR SAFETY. ALL PRODUCTS ARE SUBJECT TO THIS FULL DISCLAIMER: <http://www.ihiconnectors.com/disclaimer.html> FOR FURTHER INFORMATION ON THE PROPER USE OF THIS PRODUCT IN SPECIFIC APPLICATIONS SEE [ihiconnectors.com/GuideToFlexFlexibleFineStrandedWireCableMechanicalLugsFAQ.html](http://ihiconnectors.com/GuideToFlexFlexibleFineStrandedWireCableMechanicalLugsFAQ.html) [ihiconnectors.com/Precautions-when-using-SMT.pdf](http://ihiconnectors.com/Precautions-when-using-SMT.pdf) [ihiconnectors.com/FAQ\\_SMT\\_SMD\\_High\\_CurrentPCB\\_Terminal\\_LugsSolderCreep.htm](http://ihiconnectors.com/FAQ_SMT_SMD_High_CurrentPCB_Terminal_LugsSolderCreep.htm) [ihiconnectors.com/NOTESonPCBFootPrintLayouts\(SMT-SMD-Mode\).pdf](http://ihiconnectors.com/NOTESonPCBFootPrintLayouts(SMT-SMD-Mode).pdf) [ihiconnectors.com/High\\_Amp\\_Wide\\_Trace\\_PCB\\_Wire\\_Connection.html](http://ihiconnectors.com/High_Amp_Wide_Trace_PCB_Wire_Connection.html) [ihiconnectors.com/Technical-Data-Installation.htm](http://ihiconnectors.com/Technical-Data-Installation.htm)